

Product	Page No.
Panel Information	
Mini/Maxi-Batten Panel Profiles.....	PMB-2
Panel Overview	PMB-2
Flashing Profiles	
Eave	PMB-3
Extended Eave	PMB-3
Cleat	PMB-3
Offset Cleat.....	PMB-3
Starter.....	PMB-3
Box Gutter	PMB-3
Box Gutter End.....	PMB-3
Universal Gutter/Downspout Strap	PMB-3
4" x 3 1/2" Downspout.....	PMB-3
4" x 3 1/2" 95° Elbow.....	PMB-3
Downspout Bracket	PMB-3
Valley	PMB-3
Rake	PMB-3
Rakewall.....	PMB-3
Counter Flashing	PMB-3
Reglet Flashing.....	PMB-4
11" Ridge/Hip Cover	PMB-4
Vented Ridge Cover	PMB-4
Vent Drip.....	PMB-4
Peak	PMB-4
Pitch Break	PMB-4
Outside Corner	PMB-4
Inside Corner.....	PMB-4
Gravel Stop.....	PMB-4
Coping	PMB-4
1.5" Sill/Head.....	PMB-4
2.25" Sill/Head.....	PMB-4
1.5" Sill to Soffit.....	PMB-4
2.25" Sill to Soffit	PMB-4
1" Z-Closure	PMB-4
1.5" Z-Closure	PMB-5
Accessory Profiles	
5/8" Curved Mini-Batten Clip	PMB-5
1" Mini-Batten Clip.....	PMB-5
1.5" Mini-Batten Clip.....	PMB-5
Maxi-Batten Clip	PMB-5
Bearing Plate.....	PMB-5
Tube Sealant	PMB-5
Tape Sealant.....	PMB-5
Rubber Roof Jack.....	PMB-5
Touch-Up Paint.....	PMB-5
Metal Panel Hemming Tool.....	PMB-5
Vent Material.....	PMB-5
Testing Information	
UL 580 Wind Uplift Information.....	PMB-6
UL 263 Fire Resistance Ratings	PMB-7
Design/Installation Considerations	
Fastener Installation Technique.....	PMB-8
Condition of Substructure.....	PMB-8
Ventilation.....	PMB-9
Panel Applications	PMB-9

Product	Page No.
Detail Conditions	
Eave with Offset Cleat Detail.....	PMB-10
Extended Eave Detail.....	PMB-11
Gutter with Offset Cleat Detail	PMB-11
Valley with Offset Cleat Detail	PMB-12
Slope Change Detail.....	PMB-13
Transition Detail.....	PMB-13
Rake Detail.....	PMB-14
Rakewall with Counter Detail.....	PMB-15
Rakewall with Reglet Detail.....	PMB-15
Endwall with Counter Detail.....	PMB-16
Endwall with Reglet Detail.....	PMB-16
Peak Detail	PMB-17
Vented Ridge Detail.....	PMB-17
11" Ridge/Hip Detail.....	PMB-18

MINI/MAXI-BATTEN PANEL OVERVIEW

PANEL PROFILES

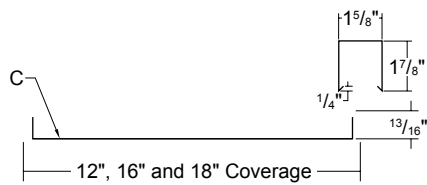
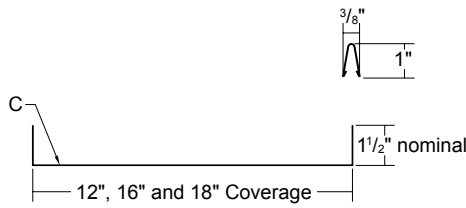
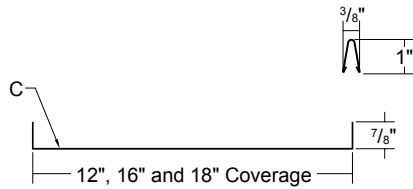

CURVING SPECS.

1" Mini-Batten: 12", 16" and 18"
 Minimum Radius : 4'-0" Pan & Batten
 For panel lengths over 25'-0", please inquire
 24 gauge only

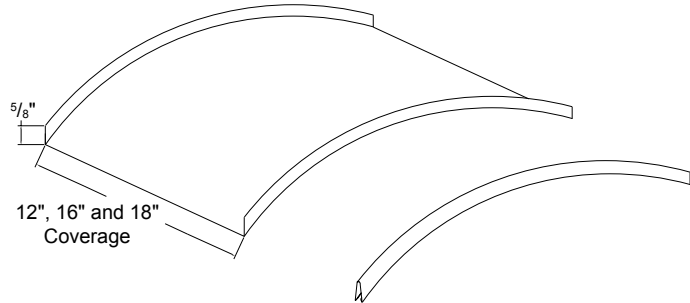

SLOPE

The minimum recommended slope for Mini/Maxi-Batten roof panel is 3:12.

SUBSTRATE

The recommended substrate is 5/8" plywood with a 30 pound felt moisture barrier. To avoid panel distortion, use a properly aligned and uniform substructure. **Please note that Mini/Maxi-Batten panels are not recommended for use over open framing.**

COVERAGE

Mini-Batten panels have coverage width of 12", 16" and 18" with 1" and 1.5" rib heights.
 Maxi-Batten panels have coverage width of 12", 16" and 18" with 1 7/8" rib height.

LENGTH

Lengths under 5'-0" are available with some cutting restrictions. Maximum recommended panel length is 45'-0". Longer panels require additional consideration in packaging, shipping and erection. Please consult your Metal Sales branch for recommendations (see PGI-2 and PGI-3 for locations). The minimum radius of Mini-Batten panels and caps is 4'-0". For Curved panel lengths over 25'-0", please inquire.

AVAILABILITY

Mini/Maxi-Batten panels are available in 26 and 24 gauge.

APPLICATION

Architectural and Residential Panel

PERFORMANCE TEST

UL 580, UL 2218, UL 790 and UL 263

FASTENING SYSTEM

Concealed Clip System

FASTENERS

The fastener selection guide should be consulted for choosing proper fasteners for specific applications. Quantity and type of fastener must meet necessary loading and code requirements (see PGI-12 through PGI-13).

MATERIALS

26 and 24 gauge steel: Grade 50 per ASTM A 792

FINISH

- ▶ *Acrylic Coated Galvalume® (ACG), AZ55 per ASTM A 792
- ▶ Prepainted Galvalume®, AZ50 per ASTM A 792
- ▶ **PVDF

* Differential appearance of Acrylic Coated Galvalume® roofing materials is not a cause for rejection.

** Meets both Kynar 500® and Hylar 5000® specifications.

EAVE

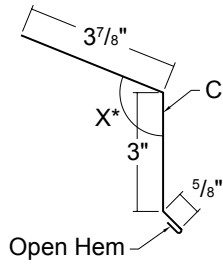

Length 10'-2" - *Specify Slope Angle

EXTENDED EAVE

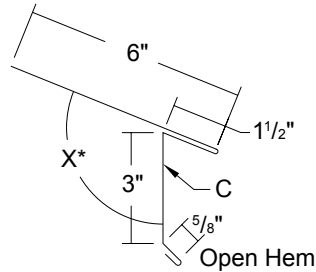

Length 10'-2"

CLEAT

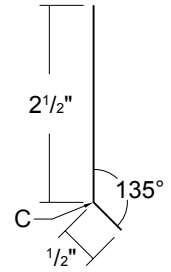

Length 10'-2"

OFFSET CLEAT

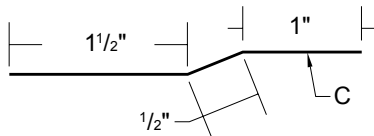

Length 10'-2"

STARTER

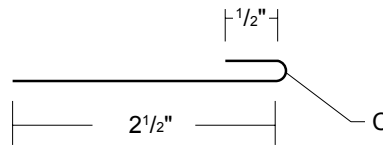

Length 10'-2"

BOX GUTTER

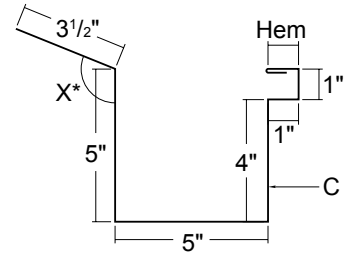

Lengths 10'-2" and 20'-3"
*Specify Slope Angle

BOX GUTTER END

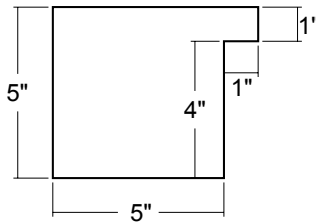

**UNIVERSAL GUTTER/
DOWNSPOUT STRAP**

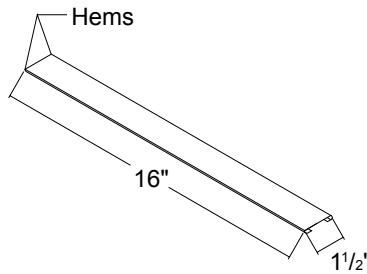

4" x 3 1/2" DOWNSPOUT

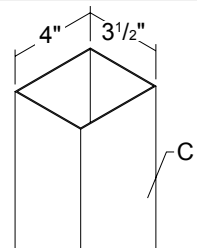

Lengths 10'-2" and 20'-3"
(6" x 4" is also available)

4" x 3 1/2" 95° ELBOW

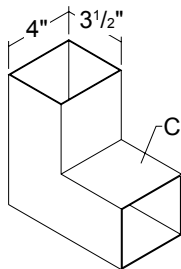

(6" x 4" is also available)
(45° is also available)

DOWNSPOUT BRACKET

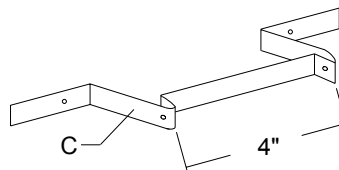

(6" is also available)

VALLEY

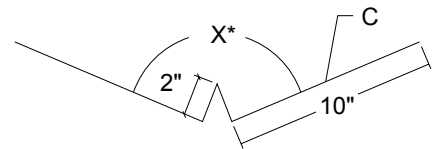

Lengths 10'-2" and 20'-3"
*Specify Slope Angle

RAKE

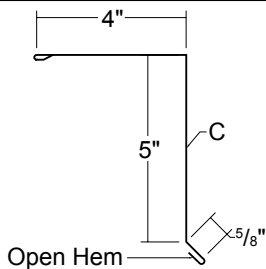

Lengths 10'-2" and 20'-3"

RAKEWALL

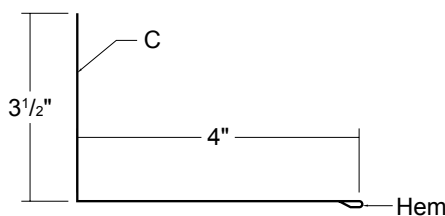

Length 10'-2"

COUNTER FLASHING

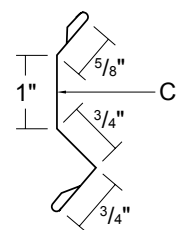

Length 10'-2"

MINI/MAXI-BATTEN FLASHING PROFILES (CONT.)

REGLET FLASHING

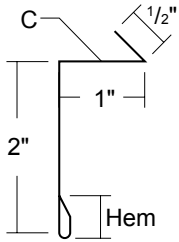

Length 10'-2"

11" RIDGE/HIP COVER

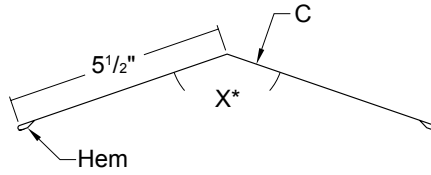

Lengths 10'-2" and 20'-3"
*Specify Slope Angle

VENTED RIDGE COVER

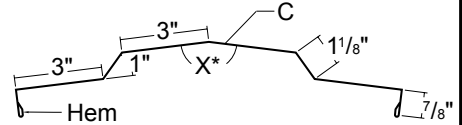

Lengths 10'-2" and 20'-3"
*Specify Slope Angle

VENT DRIP

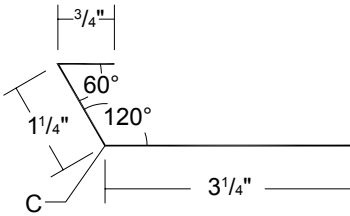

Length 10'-2"

PEAK

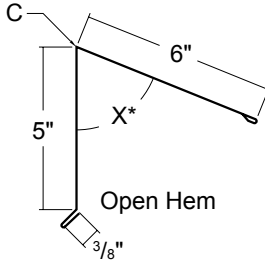

Lengths 10'-2" and 20'-3"
*Specify Slope Angle

PITCH BREAK

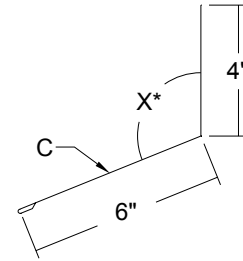

Length 10'-2" - *Specify Slope Angle

OUTSIDE CORNER

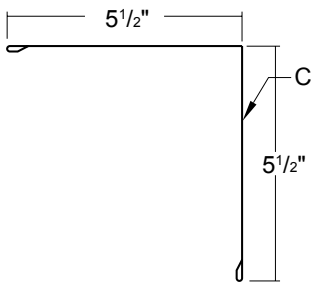

Lengths 10'-2" and 20'-3"

INSIDE CORNER

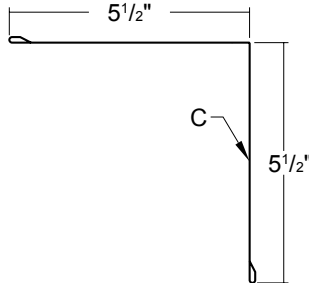

Lengths 10'-2" and 20'-3"

GRAVEL STOP

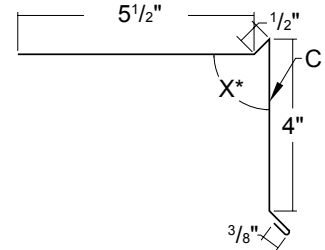

Lengths 10'-2" and 20'-3"
*Specify Slope Angle

COPING

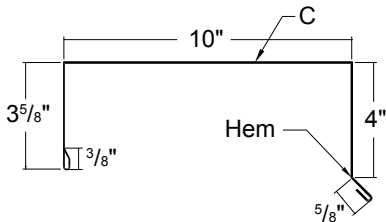

Lengths 10'-2" and 20'-3"

1.5" SILL/HEAD

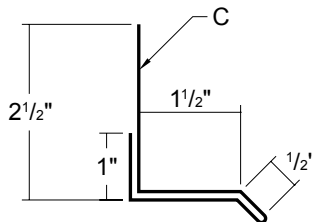

Length 10'-2"

2.25" SILL/HEAD

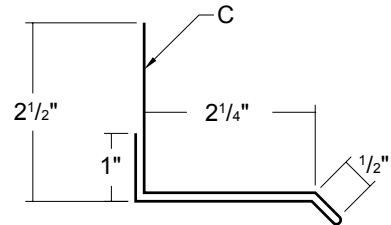

Length 10'-2"

1.5" SILL TO SOFFIT

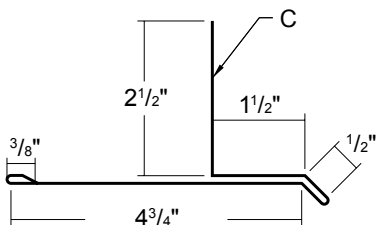

Length 10'-2"

2.25" SILL TO SOFFIT

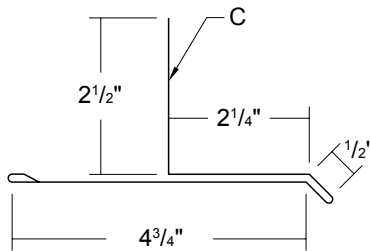

Length 10'-2"

1" Z-CLOSURE

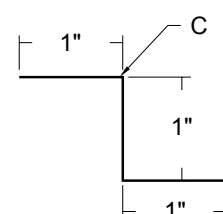

Length 10'-2"

MINI/MAXI-BATTEN

FLASHING PROFILES (CONT.)

1.5" Z-CLOSURE

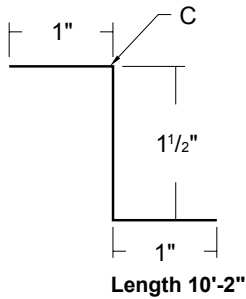

C- Indicates color side of flashing.

MINI/MAXI-BATTEN

ACCESSORY PROFILES

5/8" CURVED MINI-BATTEN CLIP

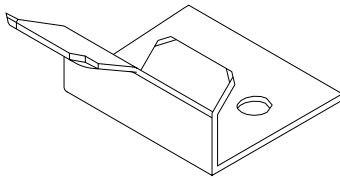

1" MINI-BATTEN CLIP

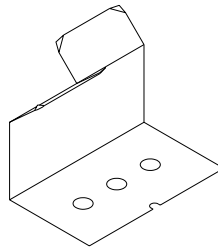

1.5" MINI-BATTEN CLIP

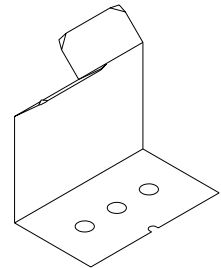

MAXI-BATTEN CLIP

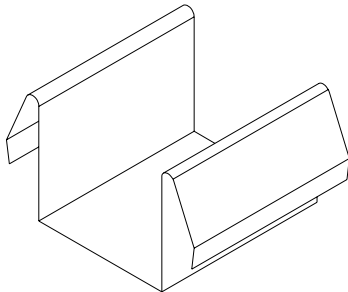

BEARING PLATE

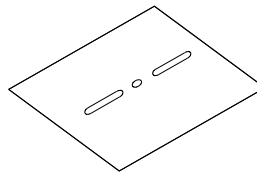

4" x 5" x 20 gauge

TUBE SEALANT

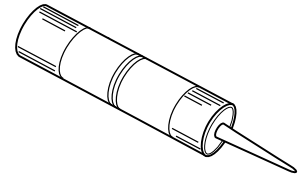

10.3 oz. Cartridge
Urethane

TAPE SEALANT



7/8" X 3/16" X 25'
Double Bead Tape Sealant
Butyl - Gray

RUBBER ROOF JACK

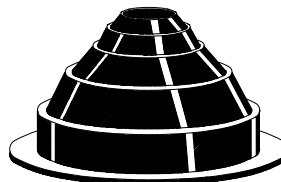

Mini (1/4" to 1/8" O.D. Pipe)
#2 (1 3/4" to 3" O.D. Pipe)
#4 (3" to 6" O.D. Pipe)
#6 (6" to 9" O.D. Pipe)
#8 (7" to 13" O.D. Pipe)

TOUCH-UP PAINT

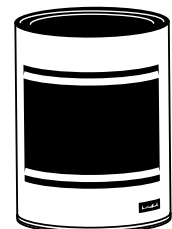

Available in pints
PVDF / MS Colorfast45®

METAL PANEL HEMMING TOOL

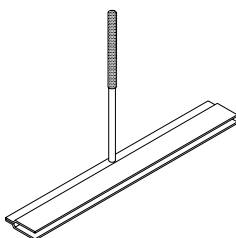

VENT MATERIAL

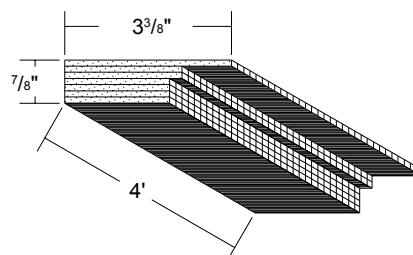

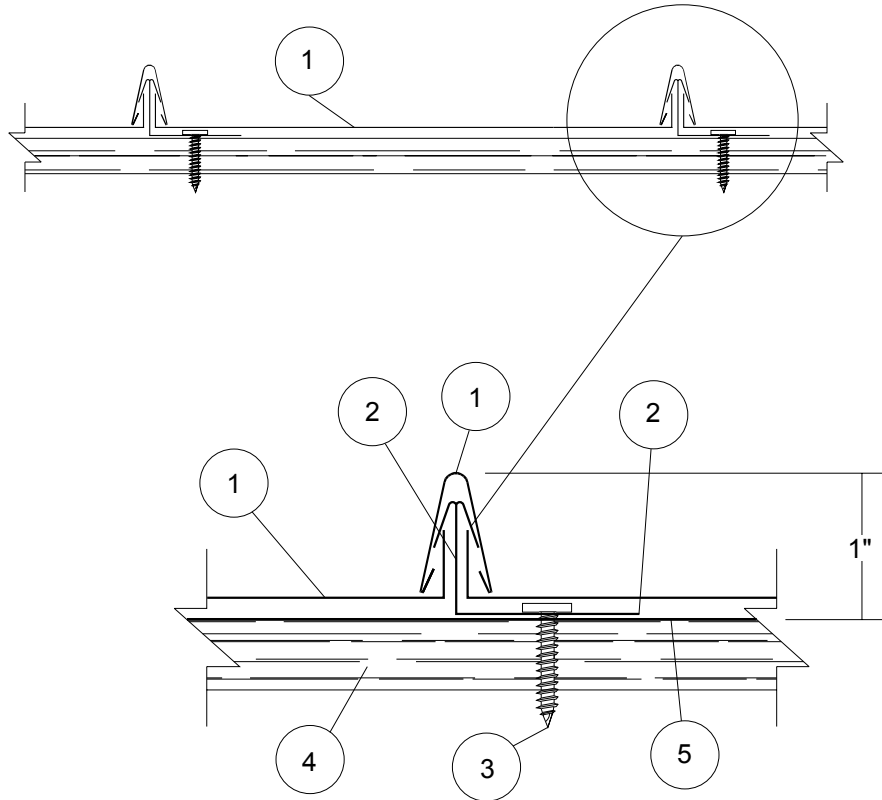

MINI-BATTEN 1"

Construction No. 430
 March 24, 1998
 Uplift - Class 90
 Fire Not Investigated

1. Metal Roof Deck Panels* No. 24 MSG min coated steel. Max panel width 22-3/4 in. and rib height 7/8 in. Panels continuous over two or more spans. End laps to occur adjacent to supports with panels overlapped min 4 in. A line of sealant may be used at panel ends and side laps.

METAL SALES MANUFACTURING CORPORATION - "Mini-Batten 1 Inch Panel"

1A. Panel Cap* Cap covering panel ribs and clips to be 3/8 in. wide and 1 in. high formed from the same type and thickness material as that used to fabricate metal panels (Item 1).

METAL SALES MANUFACTURING CORPORATION - "Mini-Batten 1 Inch Panel Cap"

2. Roof Deck Fasteners* - (Panel Clips) One piece clip, 7/8 in. high and 2-3/16 in. wide, before field forming, around panel corrugations and 2 in. long. Clips are spaced max 24 in. OC, located at the panel sides with guide holes in bottom to accommodate screw fasteners (Item 3).

METAL SALES MANUFACTURING CORPORATION - "Low Mini-Batten Panel Clip"

3. Fasteners - (Screws) Screws used to attach the panel clips to plywood to be No. 10-12 by 1 in. long Pancake head wood screw with a No. 2 Phillips Drive and A-Point. Min one screw per clip. Screws used to attach plywood substructure (Item 4) to wood trusses or joists (Item 6) to be No. 8 by 2 in. Bugle head screws with No. 2 Phillips Drive and S-Point. As an optional fastener, 2-1/2 in. long 8d common deformed shank nails may be used. Spacing of screws or nails to be 6 in. O.C. at plywood ends and 12 in. O.C. at interior connections.

4. Substructure - (Plywood) Plywood decking to be nom 5/8 in. thick, exposure sheathing span C-D, 40/20 plywood. (All joints to be sealed against leakage by using tape and/or caulk.

5. Felt Paper (Optional) - One or two ply, 30 lb organic felt.

6. Joists - (Wood) (Not shown) - Wood joists to support plywood spaced at 2 ft 0 in. O.C. may be one of the following:

A. Nom 2 by 6 in. wood joists No. 2 or better.

B. Nom 2 by 4 in. wood when used on a top cord of a wood truss, No. 2 or better.

C. Light gauge structural steel framing with the member against the plywood to be a min No. 22 MSG coated steel, or Steel joists, purlins or hot rolled beams to support steel deck to run perpendicular to the direction of deck at max 6 ft 0 in. O.C., min thickness 22 MSG, sized by manufacturer to support loads.

7. Insulation (Optional) (Not shown) - Any compressible blanket insulation, 3 in. max thickness before compression. Insulation to be sandwiched between substructure (Item 4) and its support (Item 6).

Refer to General Information, Roof Deck Construction (Roofing Materials and Systems Directory) for Items Not Evaluated.

*Bearing the UL Classification Marking



Underwriters Laboratories Inc. ®

LISTED

Metal Roof Deck Panels

Metal Sales Manufacturing Corporation has obtained fire resistance ratings for various products conducted according to test criteria set forth by 'Underwriters Laboratories' "Standard Fire Tests of Building Construction and Material" (ANSI/UL 263). This test procedure is identical to ASTM E-119 and NFPA 251.

The fire resistance rating is for the total assembly and not just the external metal panel. Ratings are expressed in hours and vary depending upon the assemblies. In general, the test criteria is to evaluate the assembly's ability to continue to support the superimposed loads and resist the passage of flame, high temperatures, or hot gases which will ignite combustible materials. The test assemblies are identified by an alpha-numeric design number.

For detail information on specific assemblies and hourly ratings see UL Fire Resistance Directory.

METAL SALES MANUFACTURING CORPORATION

R9697

Mechanically attached metal roof panels - Type "Low Mini-Batten Panel and Cap" secured by steel anchor clips. Anchor clips are attached to a hat shaped member* (minimum depth 1 in.) or a bearing plate**.

For use in Design Nos. P224 , P225 , P227 , P230 , P237 , P508 , P510 , P512 , P701 , P711 , P712 , P713 , P715 , P717 , P720 , P722 , P723 , P724 , P726 , P731 , P734 , P736 , P803 , P814 , P815 , P818 , P819 , P821 , P823 , P824 .

*Hat shaped member to be a minimum of 16 gauge. The member will be fastened through the roof insulation to the steel roof deck with min. No. 14 self-drilling and/or self-tapping fasteners. Spacing to be determined by the structural loading requirements. In addition any compressible UL Classified glass fiber blanket insulation with or without a vapor retarder facing may be used between the specified roof insulation and the metal roof panels.

**Bearing plate to be a minimum of 16 gauge. Member will be fastened through the roof insulation to the steel deck with min. No. 14 self-drilling and/or self-tapping fasteners.

See the UL Fire Resistance Directory for explanation of each design number listed above.



Underwriters Laboratories Inc. ®

LISTED

FASTENER INSTALLATION TECHNIQUE

Recommended Tool Type - Use depth locating nose or adjustable clutch on screw gun to prevent overdrilling and strip out. **Do not use impact tools or runners.**

Seating the washer - Apply sufficient torque to seat the washer - do not overdrive the fastener.

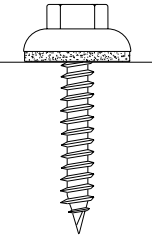
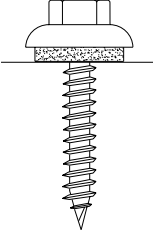
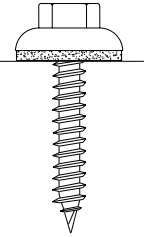
	CORRECT Sealing material slightly visible at edge of metal washer. Assembly is watertight.	TOO LOOSE Sealing material is not visible; not enough compression to seal properly.	TOO TIGHT Metal washer deformed; sealing material pressed beyond washer edge.
WOODSCREW			

To prevent wobbling - Make sure fastener head is completely engaged in the socket. If the head does not go all the way in the socket - tap the magnet deeper into the socket to allow full head engagement. Metal chips will build up from drilling and should be removed from time to time.

Protect drill point - Push only hard enough on the screw gun to engage clutch. This prevents excess friction and burn out of the drill point. Correct pressure will allow screw to drill and tap without binding.

Drilling through sheet and insulation - Ease up on pressure when drilling through insulation to avoid striking the purlin or girt with the point - apply more pressure after drill point contacts purlin or girt.

Drilling through purlin overlaps - Drilling through lapped purlins requires extra care. Excessive voids between purlins sometimes damages drill points and two self-drillers might be necessary to complete the operation. It is sometimes advantageous to predrill.

CONDITION OF SUBSTRUCTURE

Whether over solid substrate or open structural framing, panel distortion may occur if not applied over properly aligned and uniform substructure.

The installer should check the roof deck for squareness before installing Mini/Maxi-Batten panels. Several methods can be used to verify squareness of the structure for proper installation of the panels.

METHOD "A" - One method for checking the roof for squareness is to measure diagonally across one slope of the roof from similar points at the ridge and eave and obtain the same dimension.

METHOD "B" - The 3-4-5 triangle system may also be used. To use this system measure a point from the corner along the edge of the roof at a module of three (3). Measure a point from the same corner along another edge at a module of four (4). Then by measuring diagonally between the two points established, the dimension should be exactly a module of five (5) to have a square corner. Multiple uses of this system may be required to determine building squareness. If the endwall cannot be made square, the roof system cannot be installed as shown in these instructions.

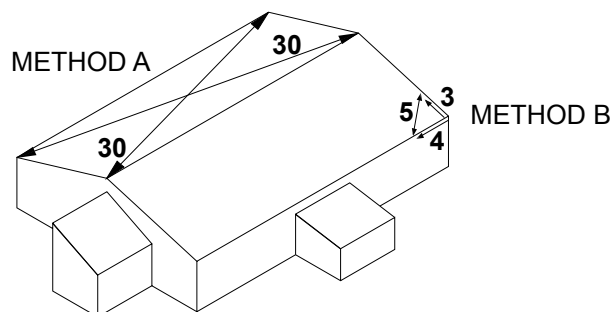

VENTILATION

Proper design and installation of vapor barriers and ventilation systems are important to prevent condensation and the resulting problems of moisture damage and loss of insulation efficiency.

Condensation occurs when moisture laden air comes in contact with a surface temperature equal to or below the dew point of the air. This phenomenon creates problems that are not unique with metal roofing; these problems are common to all types of construction.

The underside of the metal roof on a typical Architectural building should be protected from condensation by installing panels directly over a minimum 30 lb moisture barrier and uniform solid substrate. This reduces airspace and the potential of condensation forming on the underside of the panels.

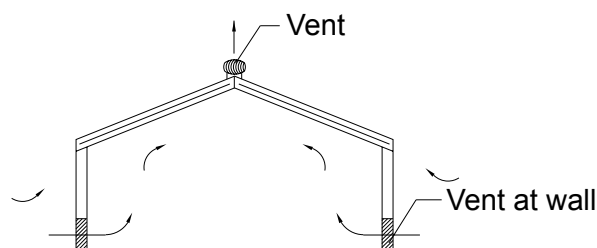

Typical metal building (no attic)

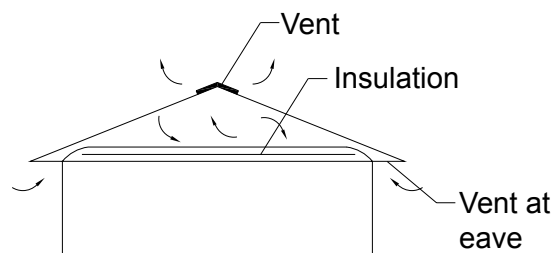

Building with attic or retrofitted

PANEL APPLICATIONS

The following chart highlights UL 580 Class 90 for clip installation on the selected applications (see Fastener Selection Guide page PGI-12 through PGI-14 for other fasteners available). For more information on UL Construction numbers, refer to UL Roofing Materials and System Directories.

PANEL TYPE	APPLICATION	INSTALLATION REQUIREMENTS		CLIP SPACING	TYPE OF FASTENER	NUMBER REQUIRED
MINI-BATTEN ¹	CLIPS OVER 5/8" WOOD DECK CONST. #430	UL 90	24 GAUGE PANEL	2'-0" O.C.**	#10-12 x 1" PANCAKE WOOD SCREW	1 FASTENER
	CLIP OVER RIGID INSULATION / METAL DECK CONST. #397A	UL 90	24 GAUGE PANEL	2'-0" O.C.**	*#14-13 x L DECK SCREW	1 FASTENER
MAXI-BATTEN	CLIPS OVER 5/8" WOOD DECK CONST. #398	UL 90	24 GAUGE PANEL	2'-0" O.C.**	#10-12 x 1" PANCAKE WOOD SCREW	1 FASTENER
	CLIP OVER RIGID INSULATION / METAL DECK CONST. #398A	UL 90	24 GAUGE PANEL	2'-0" O.C.**	*#14-13 x L DECK SCREW	1 FASTENER

* Length of Deck Screw will vary depending on the total thickness of the rigid insulation and metal decking.

** Based on UL 580. Subject to project loading, closer clip (fastener) spacing may be required. Contact your local Metal Sales branch representative for more information (see pages PGI-2 and PGI-3).

1. For 1" Mini-Batten over 5/8" plywood deck only.

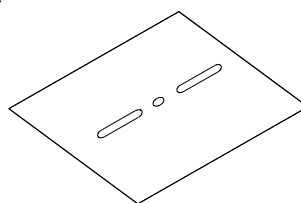

BEARING PLATE

MINI/MAXI-BATTEN EAVE WITH OFFSET CLEAT DETAIL

3:12 Minimum
Roof Slope

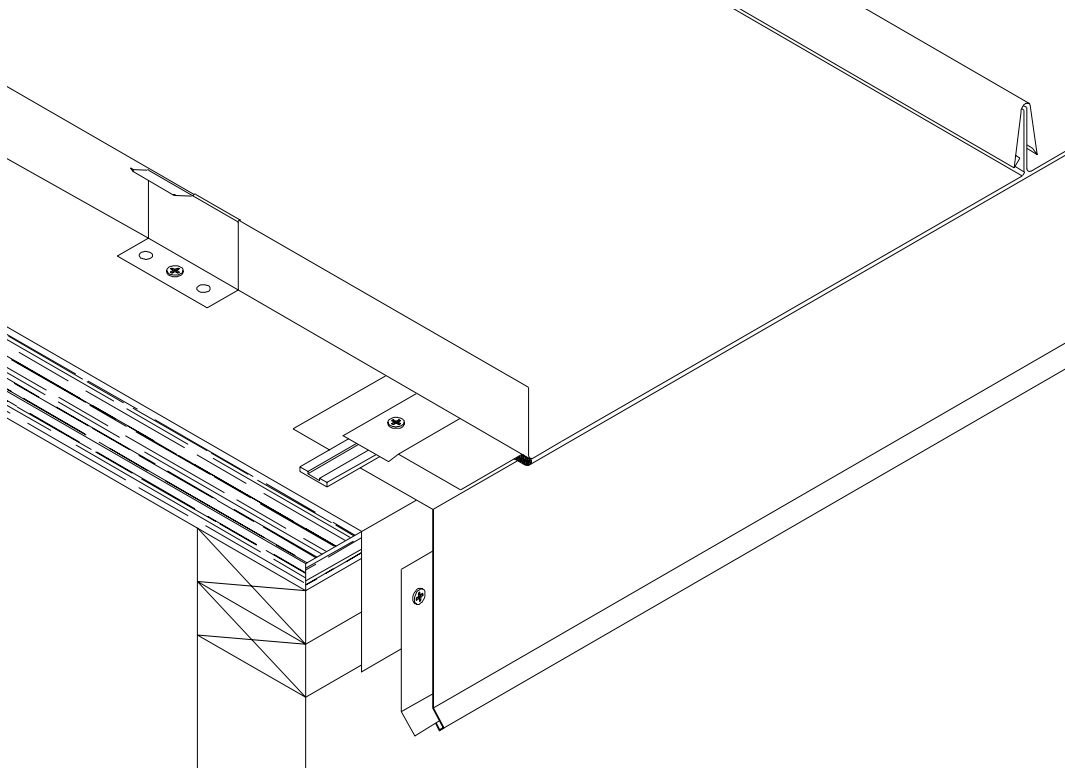
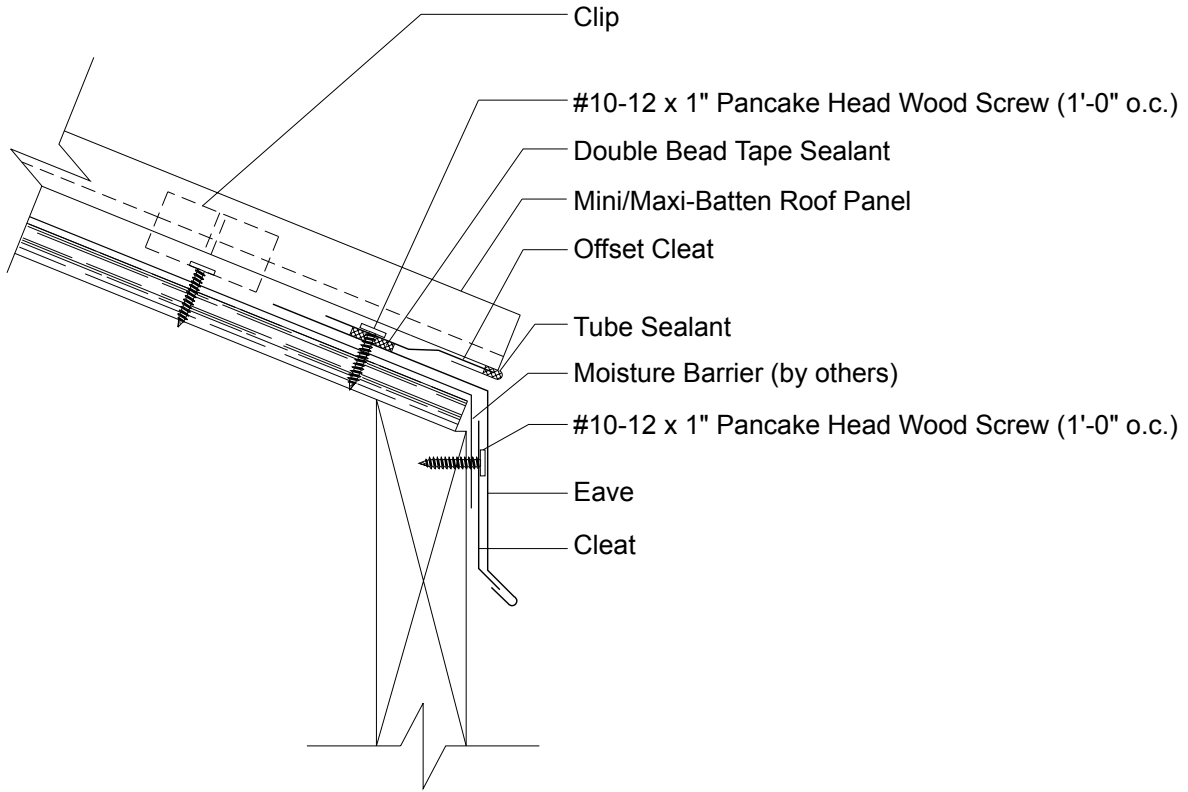

Panel rib must be field-notched and flat part of panel must be field-bent to accept Offset Cleat (see Architectural Manual).

MINI/MAXI-BATTEN EXTENDED EAVE DETAIL

3:12 Minimum
Roof Slope

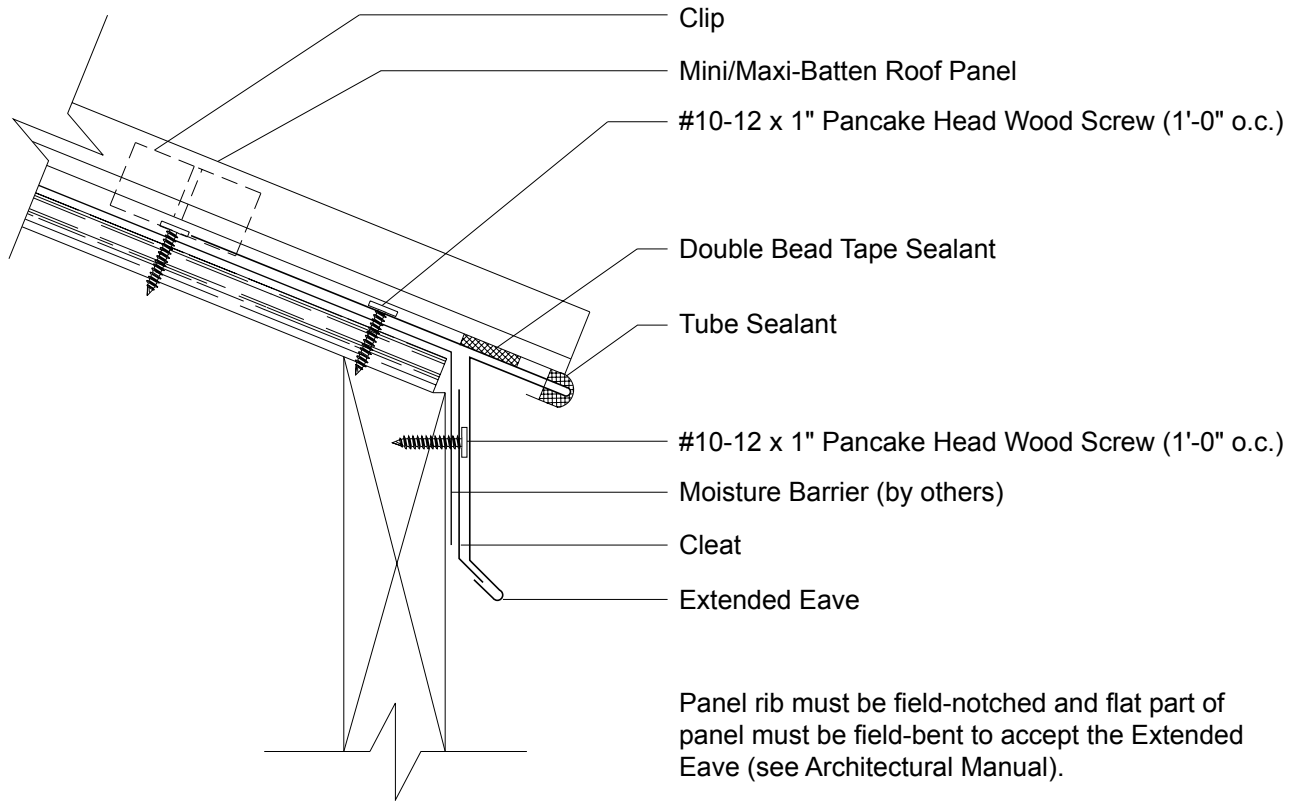

MINI/MAXI-BATTEN GUTTER WITH OFFSET CLEAT DETAIL

3:12 Minimum
Roof Slope

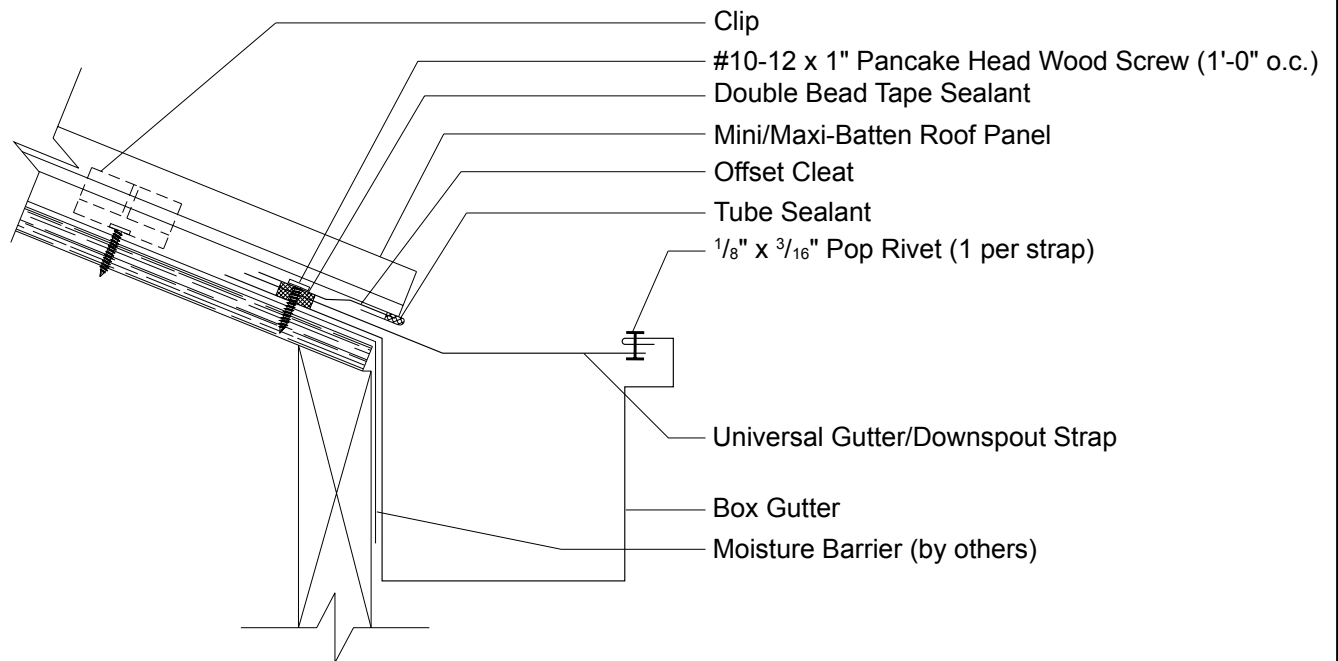

Panel rib must be field-notched and flat part of panel must be field-bent to accept Offset Cleat (see Architectural Manual).

**3:12 Minimum
Roof Slope**

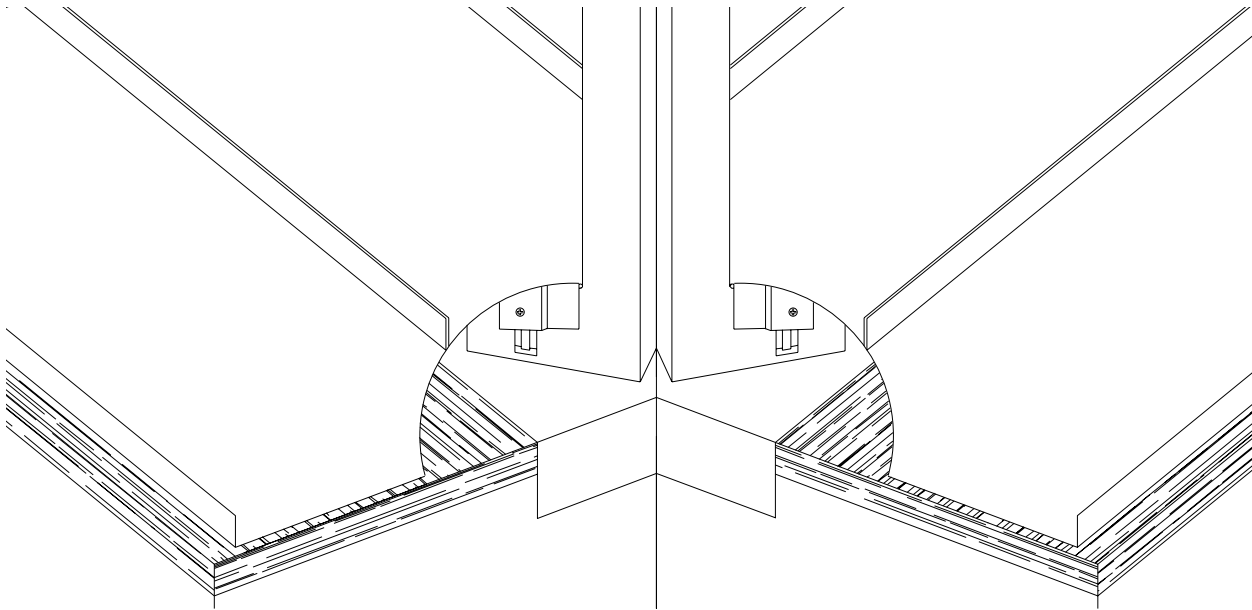
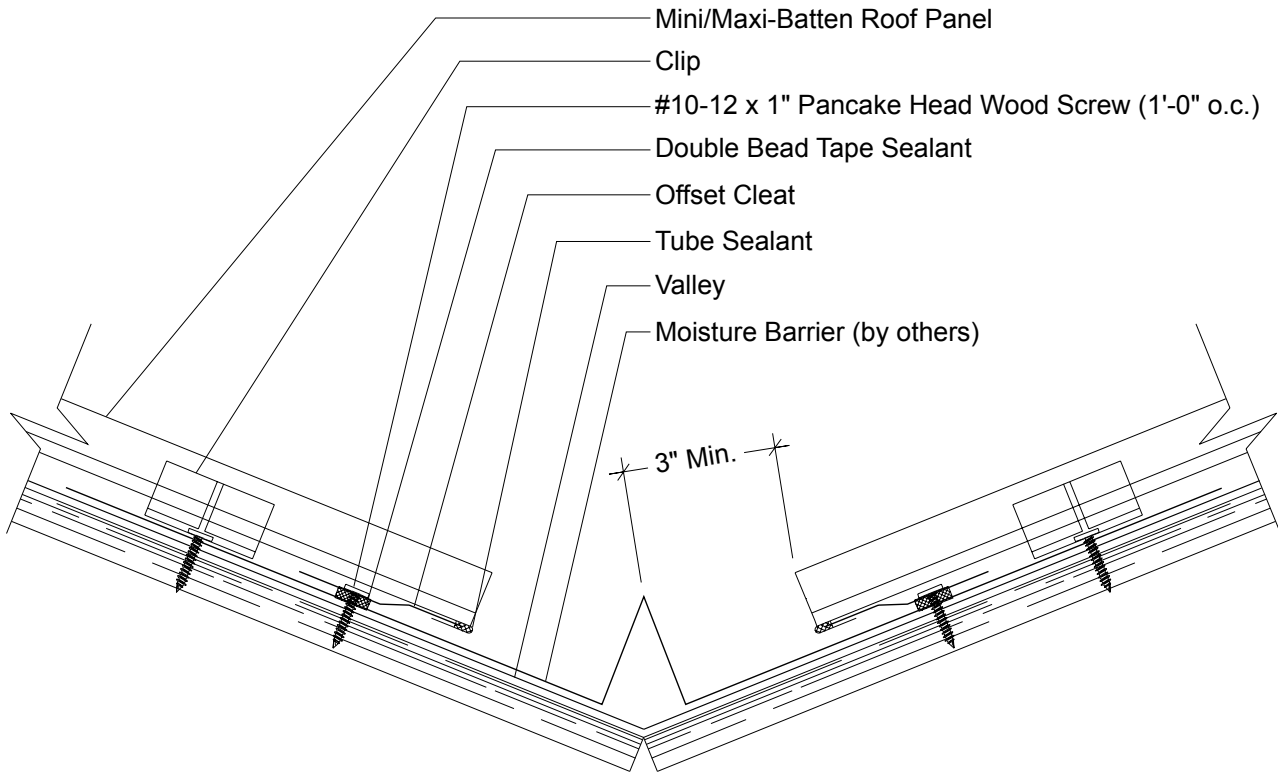

Panel rib must be field-notched and flat part of panel must be field-bent to accept Offset Cleat (see Architectural Manual).

MINI/MAXI-BATTEN

SLOPE CHANGE DETAIL

3:12 Minimum
Roof Slope

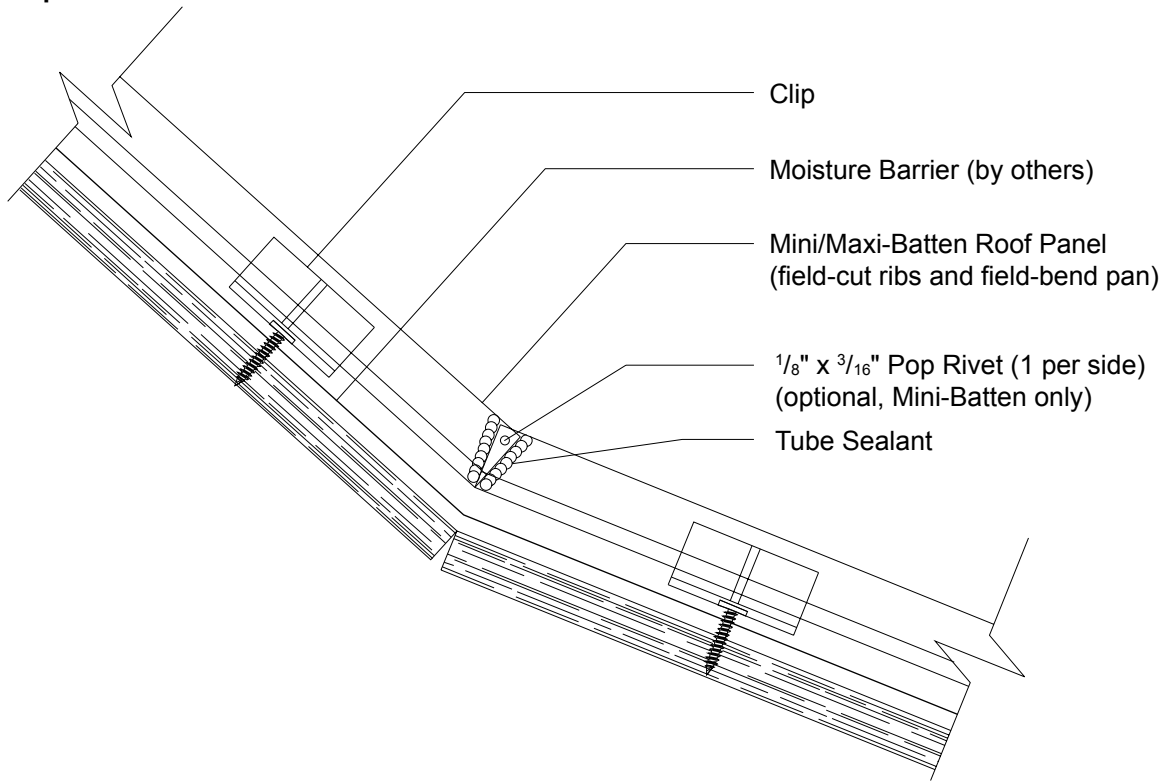

MINI/MAXI-BATTEN

TRANSITION DETAIL

3:12 Minimum
Roof Slope

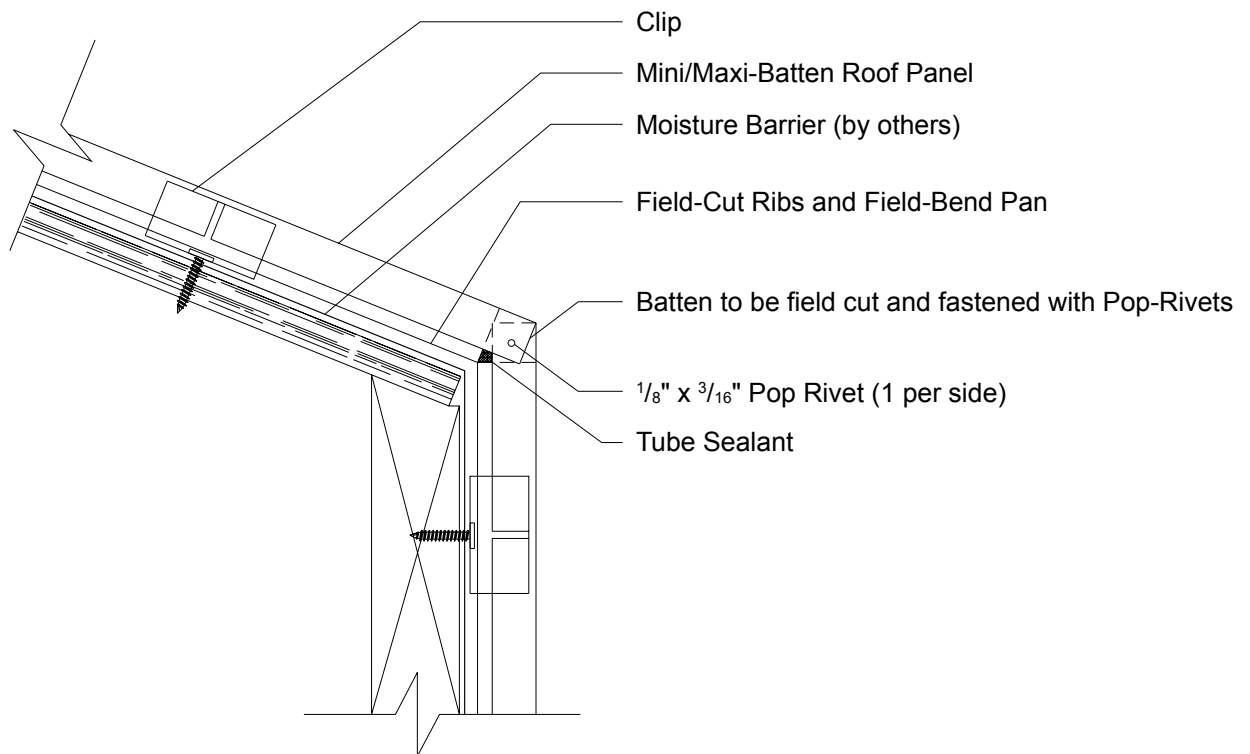

**3:12 Minimum
Roof Slope**

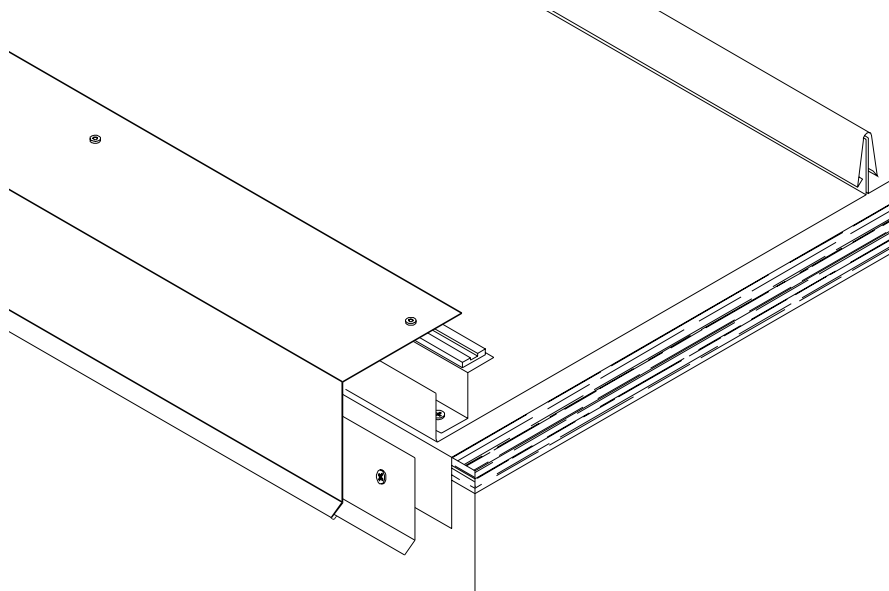
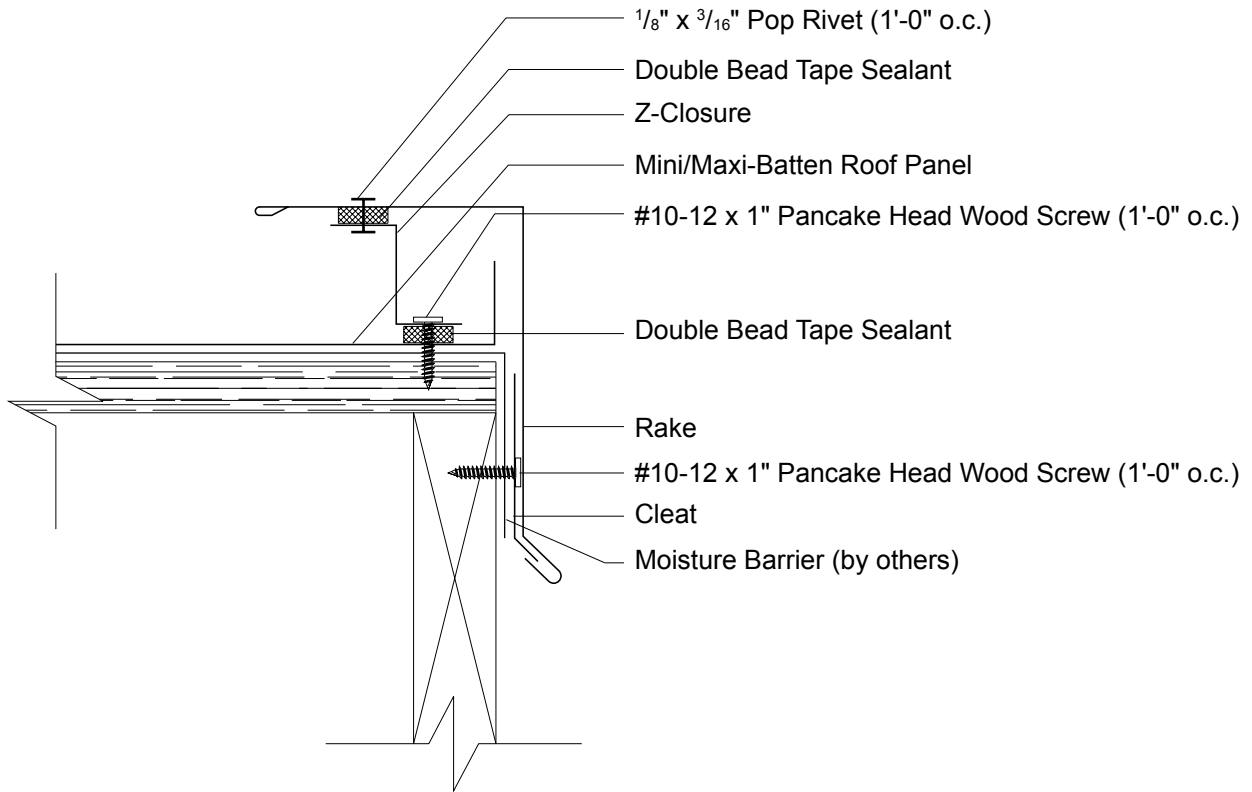

MINI/MAXI-BATTEN

RAKEWALL WITH COUNTER DETAIL

3:12 Minimum
Roof Slope

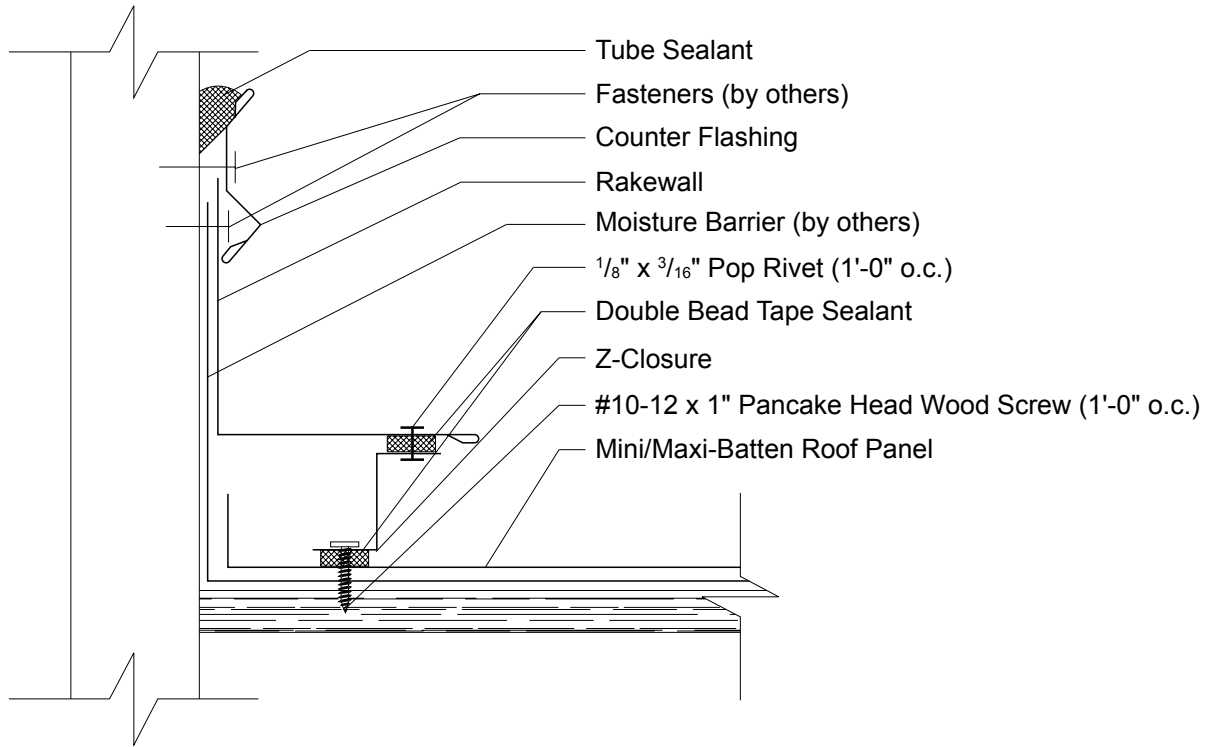

MINI/MAXI-BATTEN

RAKEWALL WITH REGLET DETAIL

3:12 Minimum
Roof Slope

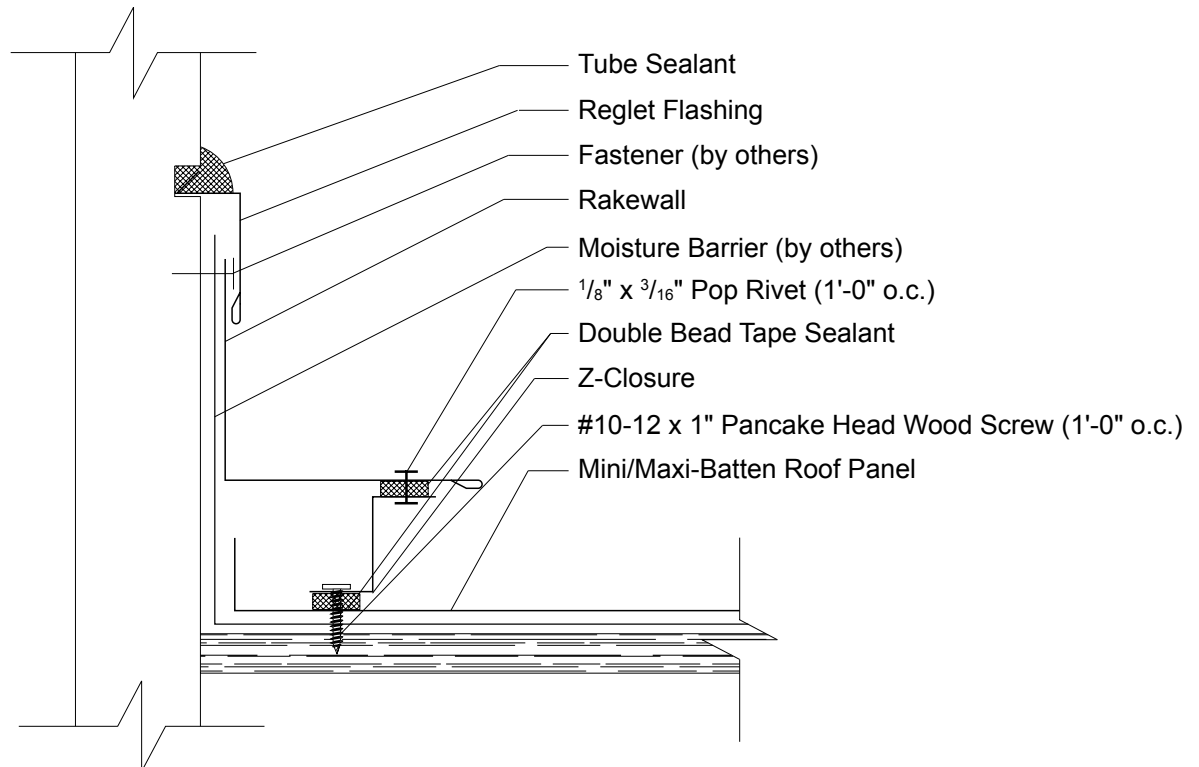

MINI/MAXI-BATTEN ENDWALL WITH COUNTER DETAIL

3:12 Minimum
Roof Slope

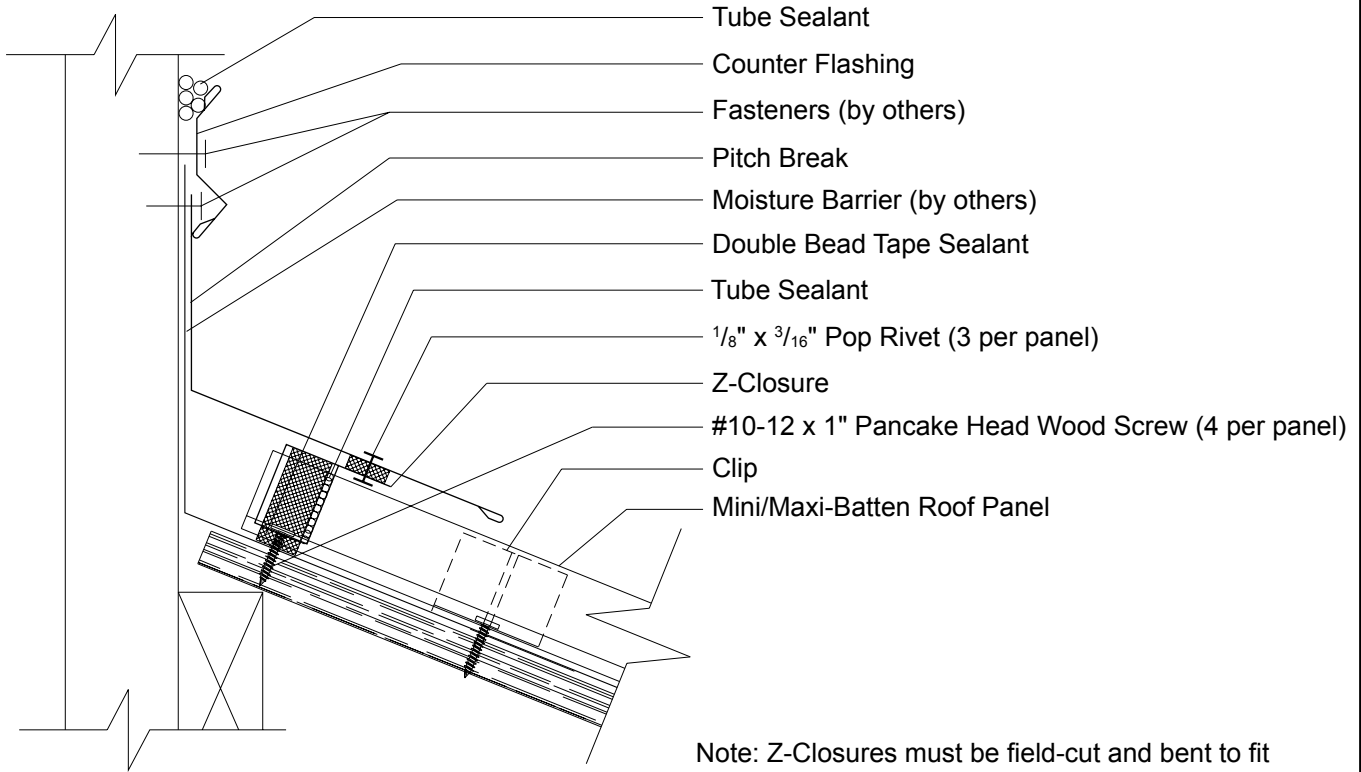

MINI/MAXI-BATTEN ENDWALL WITH REGLET DETAIL

3:12 Minimum
Roof Slope

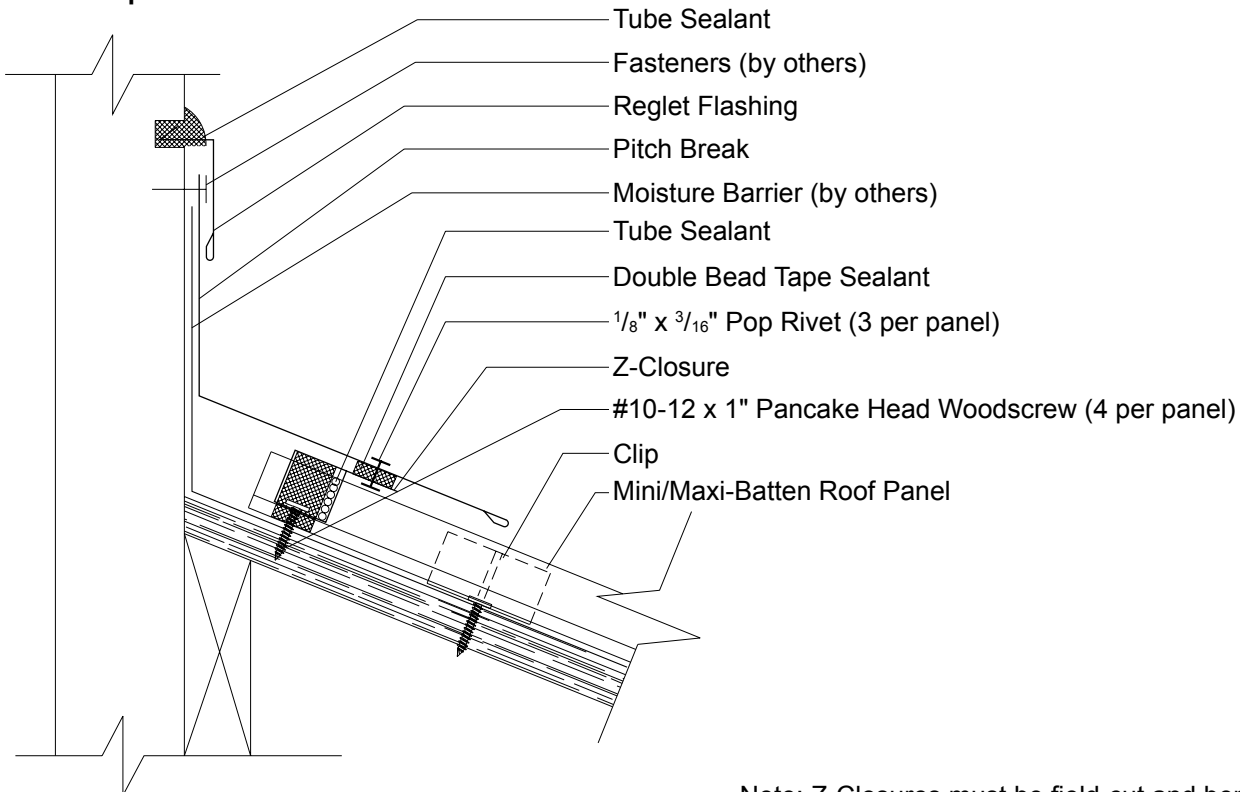

MINI/MAXI-BATTEN PEAK DETAIL

3:12 Minimum Roof Slope

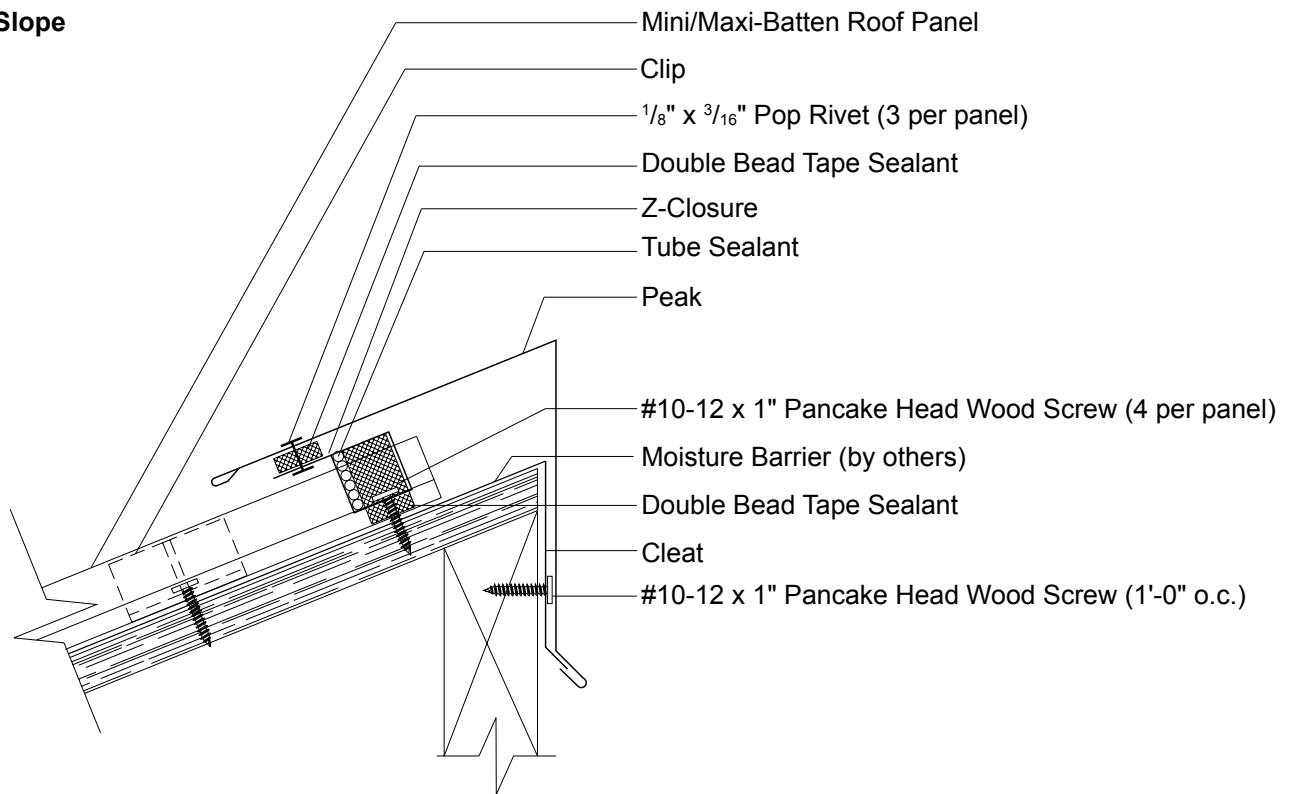

Note: Z-Closures must be field-cut and bent to fit between panel ribs (see Architectural Manual).

MINI/MAXI-BATTEN VENTED RIDGE DETAIL

3:12 Minimum Roof Slope

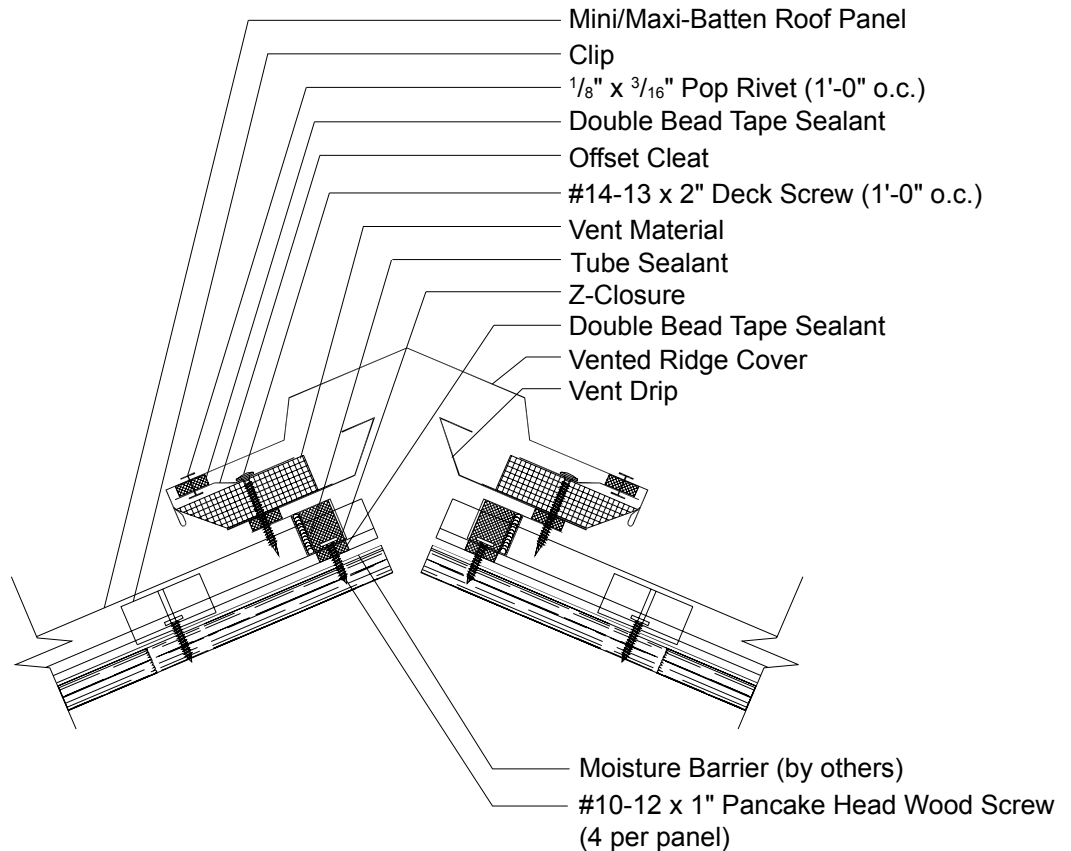

CAUTION
Additional screws may be required for high snow loading and steep slopes.

MINI/MAXI-BATTEN 11" RIDGE/HIP DETAIL

3:12 Minimum
Roof Slope

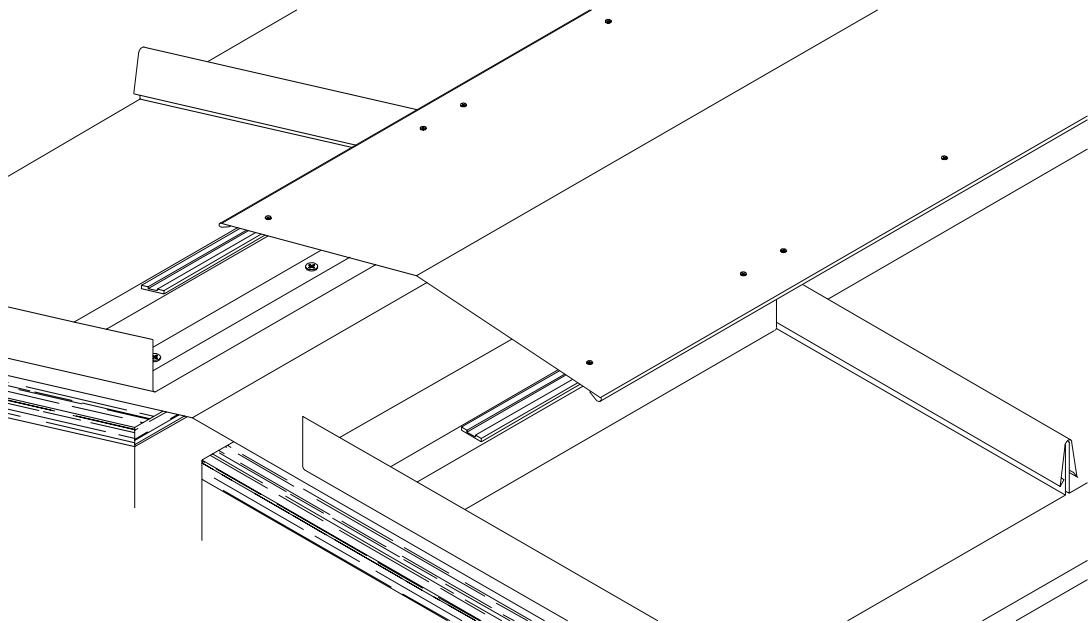
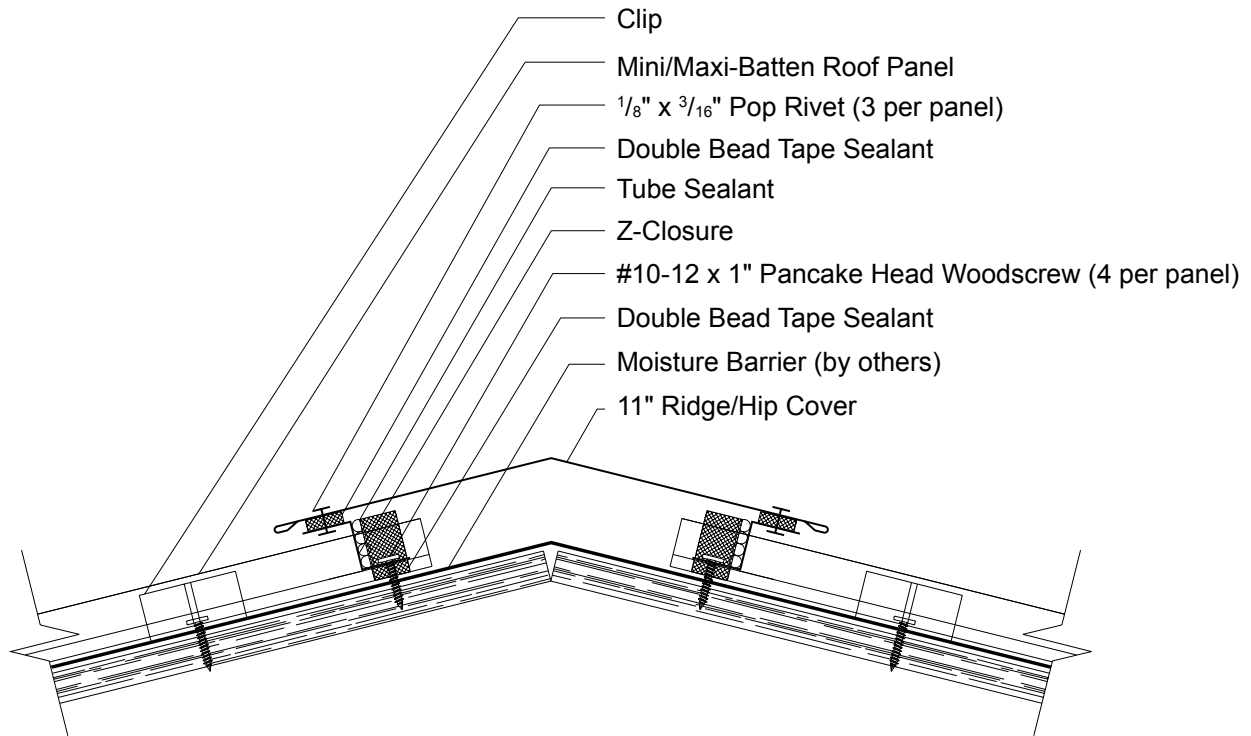

CAUTION

Additional screws
may be required for
high snow loading
and steep slopes.