

CURVED MAGNA-LOC

Condensed
Technical
Reference

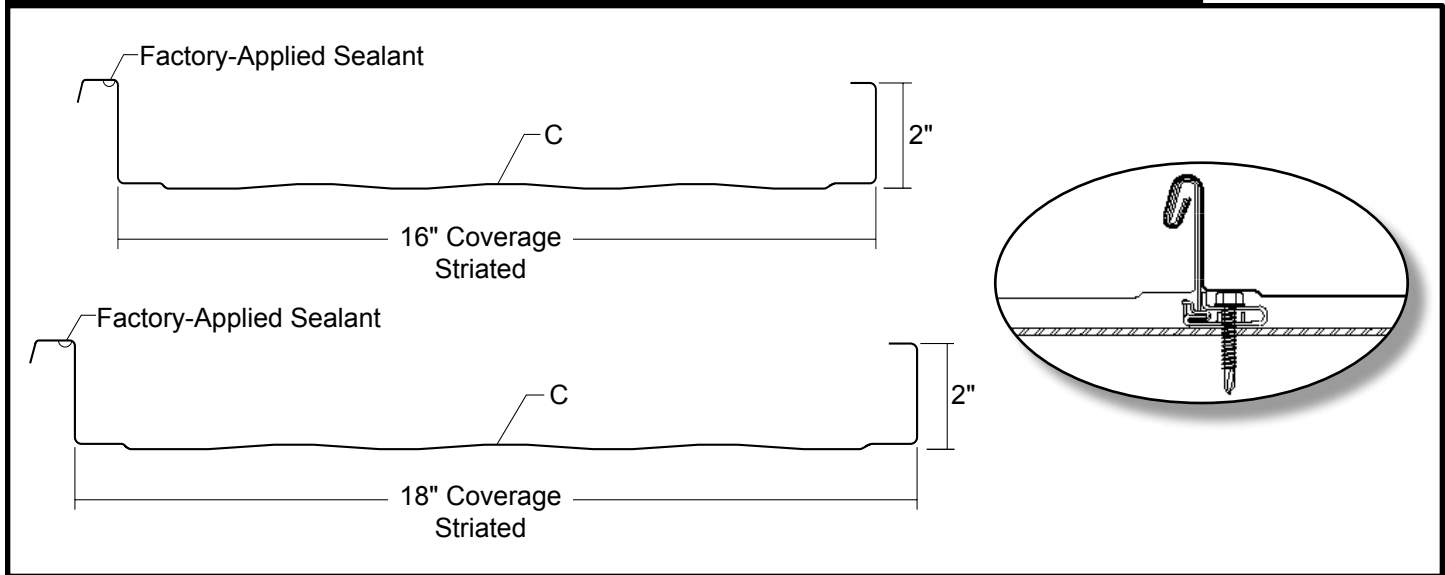

ARCHITECTURAL
COMMERCIAL
INDUSTRIAL
PANEL

CONCEALED
FASTENED

16" OR 18"
COVERAGE

MINIMUM
RADIUS
20'

OPEN FRAMING OR
SOLID SUBSTRATE

PANEL OVERVIEW

- ▶ Finishes: PVDF and Acrylic-Coated Galvalume®
- ▶ Corrosion Protection: AZ55 per ASTM A 792 for unpainted Galvalume®
AZ50 per ASTM A 792 for painted Galvalume®
G90 per ASTM A 653 for Galvanized
- ▶ Gauges: 24 ga standard; 22 ga and 20 ga optional
- ▶ 16" or 18" panel coverage, 2" rib height
- ▶ Panel Length: Minimum: 5' for striated, 7' for non-striated; Maximum: 45' recommended
- ▶ Architectural, structural vertical rib standing seam roof system
- ▶ Integral mechanically seamed side lap with factory-applied sealant
- ▶ Panels can be factory-notched and punched
- ▶ Accommodates 1/2" to 6" blanket insulation
- ▶ For 90° seam - 20' minimum radius, 110' max radius
- ▶ For 180° seam - 50' minimum radius, no max radius
- ▶ Convex curves only

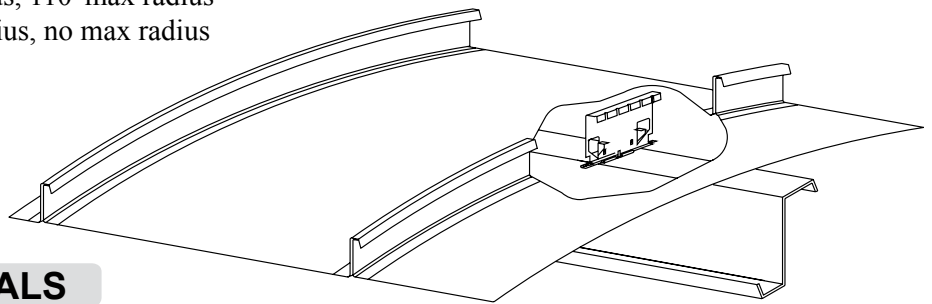

TESTING AND APPROVALS

- ▶ UL 2218 Impact Resistance - Class 4
- ▶ UL 790 Fire Resistance Rating - Class A, per building code
- ▶ UL 263 Fire Resistance Rating - per assembly
- ▶ ASTM E 1680 Air Leakage - 0.015 cfm/ft² at 6.24 psf*
- ▶ ASTM E 1646 Water Penetration - none at 12 psf*
- ▶ UL 580 Uplift Resistance - Class 90 Constructions: #576, #577 and #583

* with tube sealant at clip locations

MS metal sales[™]
manufacturing corporation

CURVED MAGNA-LOC

Condensed
Technical
Reference

ATTACHMENT DETAILS

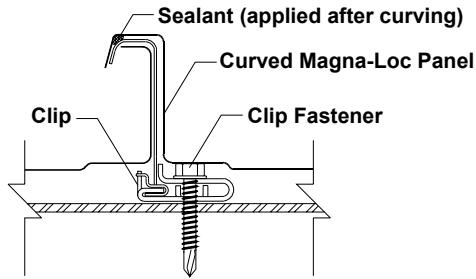

BEFORE SEAMING

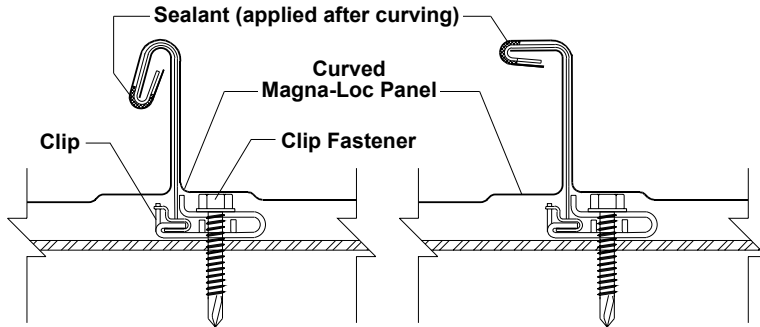

180° SEAM AFTER SEAMING

90° SEAM AFTER SEAMING

PANEL CLIP

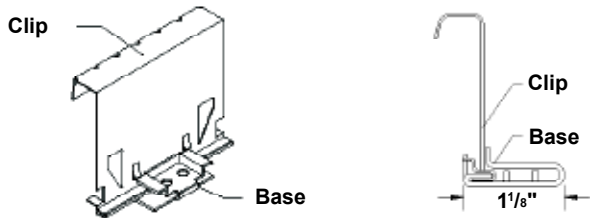

FASTENING INFORMATION

► Clips

Clip spacing is based upon the design loads, the spanning capacity of the panels, the fasteners and the support members.

Clip Tabs are 0.034" thick, G90 is standard, 410 stainless is optional. Clip base is 0.060" thick, G60.

Floating Clips can accommodate 1-1/2" of thermal movement each way.

► Fasteners

Overdriven fasteners will cause panel distortions.

Fasteners should extend 1/2" or more past the inside face of the support material.

Clip Fasteners:

Attaching to Wood:

#12-11 x 1-1/2" Wood Screw

Attaching to Steel:

<18 ga: 1/4"-14 Deck Screw

>=18 ga, <=12 ga: 1/4"-14 Driller, No Washer

>12 ga: 1/4"-24 Driller, No Washer

Exposed End Fasteners:

Attaching to Eave Plate or Back-Up Channel:

#12-14 XL Driller

Concealed End Fasteners

Attaching to Eave Plate or Back-Up Channel:

#12-14 Driller, No Washer

Trim Fasteners:

1/4"-14 x 7/8" XL Stitch Screw

1/8" x 3/16" Pop Rivet

SECTION PROPERTIES

ALLOWABLE UNIFORM LIVE LOADS, psf For various clip spacings

| Ga | Seam | Width in | Yield ksi | Weight psf | Top in Compression | | | | Bottom in Compression | | | | | | | | | | | |
|----|------|-------------|--------------|---------------|----------------------------|----------------------------|----------------------------|----------------------------|-----------------------|------|-----|--------------|-----|----|-----|------|----|------|----|----|
| | | | | | Ixx in ³ /ft | Sxx in ³ /ft | Ixx in ³ /ft | Sxx in ³ /ft | Inward Load | | | Outward Load | | | | | | | | |
| | | | | | | | | | 2' | 2.5' | 3' | 3.5' | 4' | 5' | 2' | 2.5' | 3' | 3.5' | 4' | 5' |
| 24 | 180° | 16" | 50 | 1.24 | 0.1418 | 0.0779 | 0.0720 | 0.0656 | 352 | 232 | 164 | 121 | 94 | 60 | 95 | 85 | 75 | 65 | 55 | 35 |
| 24 | 180° | 18" | 50 | 1.21 | 0.1287 | 0.0695 | 0.0640 | 0.0582 | 313 | 206 | 145 | 108 | 83 | 54 | 100 | 90 | 80 | 70 | 59 | 39 |
| 24 | 90° | 16" | 50 | 1.24 | 0.1553 | 0.0858 | 0.0885 | 0.0772 | 403 | 268 | 190 | 141 | 109 | 71 | 61 | 57 | 54 | 50 | 47 | 40 |

- Theoretical section properties have been calculated per AISI 1012 'North American Specification for the Design of Cold-Formed Steel Structural Members'. Ixx and Sxx are effective section properties for deflection and bending.
- Allowable loads are calculated in accordance with AISI 1012 specifications considering bending, shear, combined bending and shear, deflection and uplift testing on 16 ga purlins. Allowable loads consider the 3 or more equal spans condition. Allowable loads do not address web crippling, fasteners or support material. Panel weight is not considered.
- Deflection consideration is limited by a maximum deflection ratio of L/180 of span.
- Allowable loads do not include a 1/3 stress increase for wind.

ms metal sales
manufacturing corporation

metalsales.us.com

Anchorage, AK 866.640.7663
Bay City, MI 888.777.7640
Deer Lake, PA 800.544.2577
Denver, CO 800.289.7663

Detroit Lakes, MN 888.594.1394
Fontana, CA 800.782.7953
Fort Smith, AR 877.452.3915
Independence, MO 800.747.0012

Jacksonville, FL 800.394.4419
Jefferson, OH 800.321.5833
Mocksville, NC 800.228.6119
Nashville, TN 800.251.8508
Rock Island, IL 800.747.1206
Rogers, MN 800.328.9316

Seattle, WA 800.431.3470
Sellersburg, IN 800.999.7777
Sioux Falls, SD 888.902.8320
Spokane, WA 800.572.6565
Temple, TX 800.543.4415
Woodland, CA 800.759.6019